

MB-0922

6' Baker Scaffold Mobile Base
with Stabil Stop™ Technology



**BASE ONLY.
Baker Scaffold NOT included.*



Releasing the handle raises the casters, locking the base in place automatically without the need to manually lock / unlock casters.



Mobile base doubles as a cart for fast, easy transport of scaffold set.



Integrated pin-locking outriggers deploy quickly to form a stable base.



Mobile base is compatible with most baker scaffold systems on the market.

WORKLIFT USA



TM

- ▶ **Fail-safe braking feature** - when handle is released, wheels retract, engaging feet to set scaffold in place
 - ▶ No need to manually lock/unlock casters
 - ▶ Enhanced roll-away protection
 - ▶ Increased tip-over protection
- ▶ **Significant time savings** - at least 15 min/day
- ▶ Maximum height: two scaffolding units
- ▶ Integral, easily deployed outriggers used at every height for improved stability, providing superior resistance to roll-away and tip-over
- ▶ Simplifies scaffold set-up and tear down
- ▶ Doubles as a cart for easy transport of scaffold
- ▶ **Made in USA**

SPECIFICATIONS

Model	Description	Approx Width	Approx Length	Approx Height	Approx Shipped Weight
MB-0922	Mobile Base	32"	74"	13"	100 lbs

INCLUDES

Qty	Description	Approx Width	Approx Length	Approx Shipped Weight
1	detachable handle	18"	48"	6 lbs
2	ratchet straps			
3	tool shelf <i>(optional)</i>	25"	56"	22 lbs

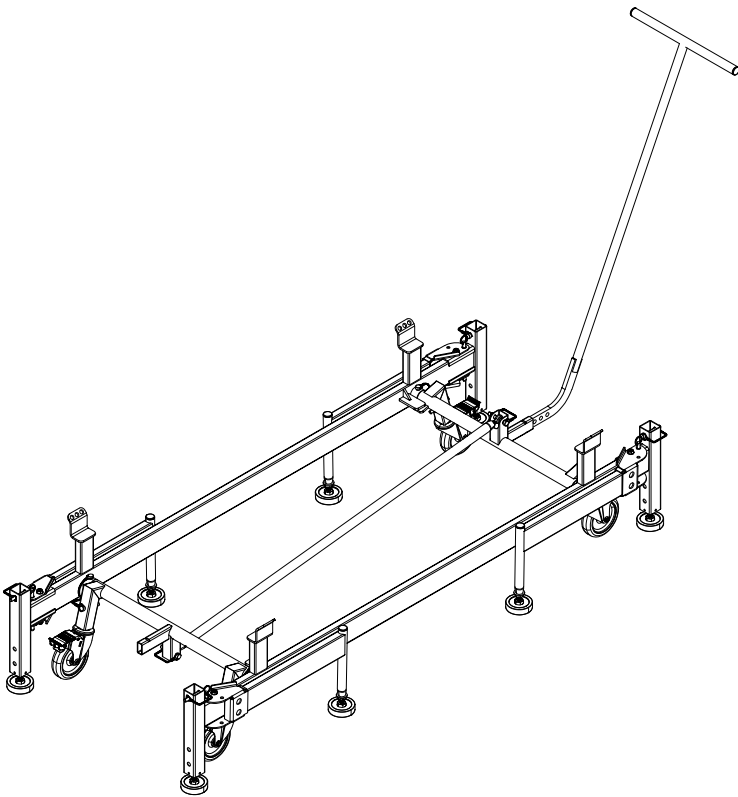

*Casters from baker scaffold may be transferred to mobile base.

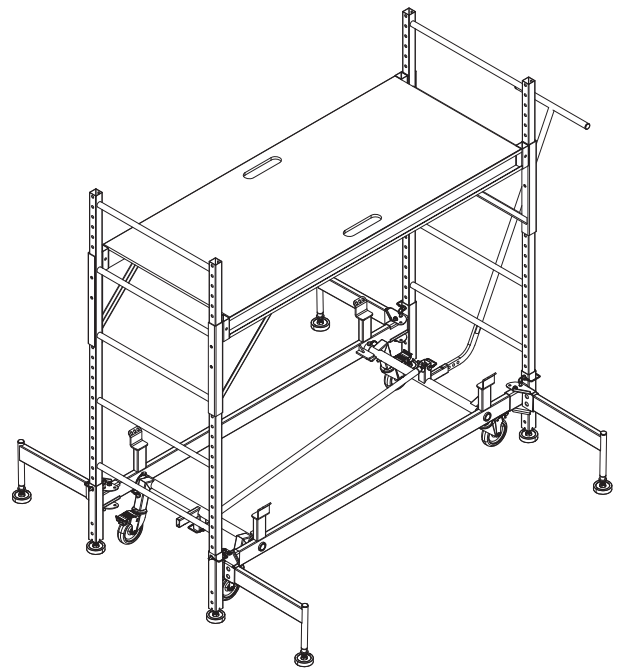

Shown with scaffold installed and outriggers deployed.

1000lbs
load capacity